

# IoT Based Safety Monitoring System in Truck Body Building Industry

V. Yuvaram<sup>a\*</sup>, R. Kandasamy, G. Selvaraj

<sup>a</sup>PG Scholar, Department of Mechanical Engineering, Selvam College of Technology, Namakkal, Tamil Nadu, India.

\*Corresponding Author Email and Phone Number: [yuvialearner@gmail.com](mailto:yuvialearner@gmail.com), +918508703293

Article received: 05/07/2022, Article Revised: 23/07/2022, Article Accepted: 24/07/2022

Doi: [10.5281/zenodo.7011970](https://doi.org/10.5281/zenodo.7011970)

© 2022 The Authors. This is an open access article distributed under the [Creative Commons Attribution License 4.0 \(CC-BY\)](https://creativecommons.org/licenses/by/4.0/), which permits unrestricted use, distribution, and reproduction in any medium, provided the original work is properly cited.

## Abstract

*There are many number of hazards identified in the daily workplace. The objective is to design a safety system to reduce these hazards in truck body building industries using IoT. For this proper hazard identification is required. In this generation, it's quite difficult to implement safety analysis techniques and address the hazardous risks in all workplace. Here different types of sensors are used to identify each hazard and microcontrollers are used to control the working of the system. For an example, temperature sensor is used to identify the temperature in industries and it shows the current updates in LCD display. If there is a rise in temperature a beeping alarm will be raised and warning message is shown in the LCD display and led starts glowing. An authorized person will have full access to and control of the entire system. An emergency exit strategy will be demonstrated to the industry's employees so they may leave the building safely. This investigation demonstrates a new solution for the Industrial safety monitoring system in truck body building industry.*

**Keywords:** Hazards, Internet of Things, Sensors, Safety, Microcontroller, LCD Display.

## 1. INTRODUCTION

The activity of making car bodies is significant. Automobile body builders, who are provided by automobile manufacturers, construct the chassis's body. The most popular type of public transportation vehicle is the truck [1]. In our nation, buses are also operated by private bus operators, travel companies, etc. On-road and off-road vehicles are the two main categories of vehicles. On-road vehicles are primarily made for driving on paved roads and highways. Trucks that go on unimproved roads or cleared land need off-road vehicles. Some truck bodyworks are made to fit trucks used in the construction, agriculture, and mining industries. Others fasten to delivery vans and vehicles, water sprayers, cable and telephone trucks, and repair tools in addition to tow trucks and wreckers [2-4]. The construction of an automobile's body requires a variety of structural designs, wood and metal-working techniques, surface protection techniques, fastening methods, and the placement of electrical and safety equipment[5-6]. Such a factory needs a wide variety of tools and machines for

working with metal and wood, testing and treating equipment, a crew that is highly productive and focused on quality, and many other amenities [7]. Body building is a labor-intensive industry where all types of employees and diligent workers are valued as assets [8].

### **1.1. Objective of this investigation**

The investigation titled “IOT BASED SAFETY MONITORING SYSTEM IN TRUCK BODY BUILDING INDUSTRY” provides an insight into Truck Body Building market in India with major focus on Manufacturing Process, Types of hazards, Safety in Workplace and Process of Truck Body Building project [9]. The report assesses the market sizing and growth of the Indian Truck Body Building Industry. Safety is the top most priority in all the industries. As the labors are the key of all industries to success [9]. A company has a moral obligation to give its employees a safe working environment. With the help of this report every employer can assure their employees to have a safe work environment [9].

## **2. INDUSTRY OVERVIEW**

Truck body shops are hazardous workplaces where employees may be hurt, injured, or even die. These can result from accidents involving electrocution, falls from heights, machinery, and equipment; being struck by moving vehicles; accidents involving manual handling and illnesses brought on by toxic substances such dust or chemicals. If stepped on while wearing the wrong shoes, even a nail protruding from a piece of wood might result in significant harm. Here the analysis was done in *Sri Amman Arul Lorry Body Labour Works, Namakkal* to know about the hazards and risks in the workplace area. Meetings were done with the workers and the employers to understand the problems and risks they face during their work and finally concluded this investigation.

## **3. EXISTING SYSTEM**

In the existing system Bluetooth and Radio Frequency technologies were employed to control and monitor industrial applications. The user has to be close enough to the Bluetooth link or close enough to the radio frequency to use it. This entire system cost high and low in efficiency. In the existing system python and embedded language is used for communicating data with the module. The data from the sensors are collected, transmitted, analyzed and finally visualized in the system. There may be any display devices like LCD display is used. The data are transmitted to the microcontroller which are processed and viewed through the Bluetooth or radio signals.

#### **4. PROPOSED SYSTEM FOR SAFETY MONITORING IN WORKPLACE**

The purpose of this investigation is to demonstrate the ability of single board computers to handle and monitor industrial equipment instead of utilizing expensive computers [2]. In this investigation we use Node MCU which is also known as ESP-32. The inputs from the sensors are sending to the Node MCU which later sent to the display device. The system's straightforward design makes it simple to integrate into an existing electrical system of a building. If desired, it is very simple to install for only one room. There aren't many changes made to the current electrical system, which lowers the cost of installation. By attaching sensors like temperature, fire and smoke sensors to the Node MCU module and turning on the built-in Wi-Fi module, the system is connected to the cloud. It uploads the sensor parameter fluctuation to the cloud. All industrial applications sensors are readily and effectively monitored through the cloud [3]. The ThinkSpeak website is accessible from a laptop or mobile device and can be used as a cloud [7]. SMS will be sent to registered users if the sensor parameter limit exceeds the chosen limit, and a warning siren will sound in the work area. In this investigation, industrial processes including Gas, Temperature, Rain, Humidity, and Fire Accidents are tracked by mobile devices and personal computers. Parameter data may be updated on a regular basis using the cloud.

##### **4.1. Major hazards in the workplace**

There are many numbers of hazards in lorry body building industry. This investigation focusing on some of the important hazards which are important to be monitored in the workplace [9] and avoid accidents which happen before.

- Temperature Hazards
- Fire Hazards
- Gas Hazards
- Rain/ Water Hazards
- Noise Hazards
- Electricity Hazards
- Humidity Hazards

These are the hazards in the truck body building industry. In these, hazards like Fire, Gas, Rain, Temperature, Humidity and Electricity can be easily monitored and avoid the accidents easily before it happens. For that continue monitoring of workplace by 24X7 is

difficult by a person and the labour expenses is also high [8]. Active monitoring is the concept introduced, which monitor the workplace by 24X7 in a year with low cost around 1500 maximum. It helps active monitoring along with the security system in the workplace area, for an example, monitor the workplace in the night time whether any persons moving in the safety lockers, Proprietor room or equipment places which avoid theft or damage in workplace.

#### 4.2. Internet of things

The Industrial Internet of Things (IoT) is the ideal method for linking industrial sensors and machines to one another over the internet, enabling the authorised user to use data from these linked devices to process the obtained data [5]. Applications that are IoT connected frequently offer data collection, aggregation, analysis, and visualisation. Modern technology like computers, intelligent gadgets, wired and wireless connectivity, and cloud computing are all included in the IoT architecture. Prior to now, short-range Bluetooth and Radio Frequency technologies were employed to control and monitor industrial applications. The user has to be close enough to the Bluetooth link or close enough to the radio frequency to use it. IoT based industry automation is a solution for short-distance communication. In this case, we have global control and monitoring capabilities [6].

#### 4.3. Proposed block diagram

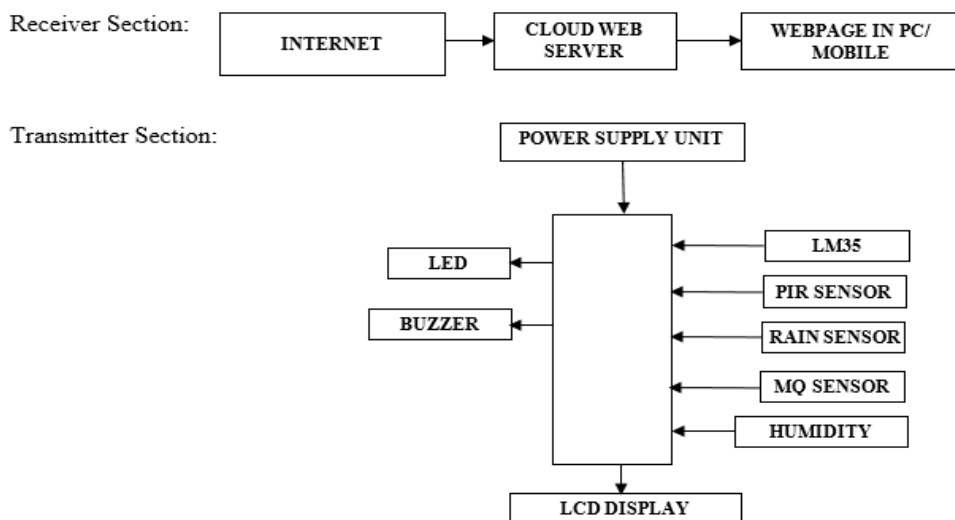

**Figure 1.** Proposed methodology layout

#### 4.4. Work process at truck body building industry

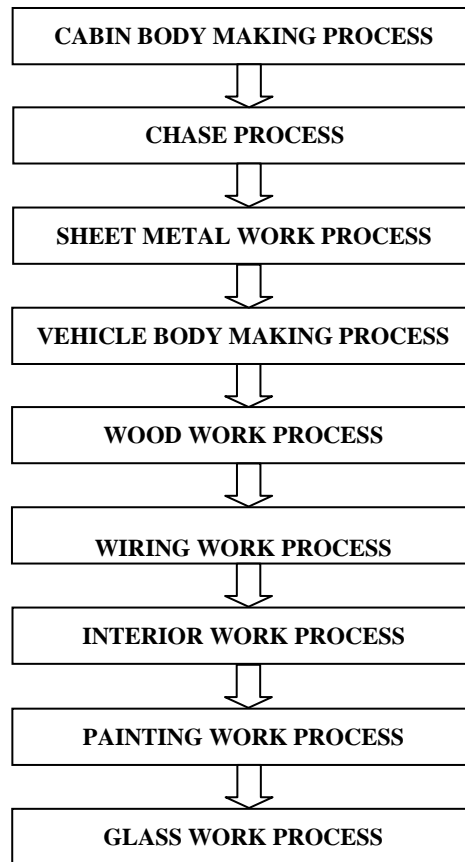

**Figure 2.** Layout of work process

#### 4.5. Methodology

In this investigation, 230V AC Current is used. In the power supply unit 230V AC Current is converted into 230V DC Current using Bridge rectifier. Then 230V DC Current is converted into 5V DC Current. This 5V supply is supplied to the Node MCU, LCD Display and all sensors like Temperature, Rain, Humidity, Gas and PIR Sensors as a parallel circuit. The values from the sensor are transmitted to the Node MCU and then it transfers data to the view readings in the LCD Display.

The parts are arranged and put together properly. The cloud is interfaced with by the hardware components through the mobile/PC. Utilizing the proposed system, mobile or PC users can monitor and control changes in the industrial parameters. Data are analyzed using the values from the sensors [1]. We define threshold values for each sensor using the cloud triggers, and when the sensors detect values higher than the threshold values, alarming

devices send SMS alerts to our mobile devices and sound a warning siren in the work area [3]. The key benefit of this idea is that we can simply operate them without the need for human beings while being able to monitor developments in the sector from anywhere [4].

Here the data is monitored and upload regularly in the cloud server of the THINGSPEAK website. There user can create a separate account. With the help of user Id and Password user can monitor and get the live data globally all over the world [7]. Locally data are monitored in the LCD display. Also, user can turn on the Buzzer and LED for danger indication in the workplace for an example if the temperature exceeds the normal temperature or if fire accident happen the LED starts to glow and buzzer starts beeping so that hazards can identified easily before it gets severe. From this investigation, user can monitor the workplace data locally and globally all over the world.

## **5. SAFETY MEASURES**

- Use lifting aids to help while lifting. Learn and employ safe lifting and shifting approaches for heavy loads.
- Refrain from inhaling welding fumes or exhaust fumes.
- Use good-quality glasses while welding to avoid eye irritation.
- Use gloves resistant to chemicals to protect your hands.
- If a person is exposed to sunshine or radiation while at work, job rotation should be offered.
- Avoid doing electrical and wiring works during rainy times and in watery places.
- Wear required PPE while working.
- Workplace inspection should be done regularly.

## **6. CONCLUSION AND FUTURE SCOPE**

This investigation helps to identify the major hazards in the truck body building industries. With the Hazard Identification and Risk Assessment (HIRA), everyone can avoid major accidents in the work place. Here sensors are used to identify those risks and create a simple tool to make an alarm to intimate the hazards to the workers. From this, everyone can act if emergency arises and avoid major accidents and reduce financial losses to the company.

The investigation demonstrated how the system was implemented successfully utilising the Node MCU as the primary microcontroller. Today, the internet is the only source

of human life. The majority of the job will be done exclusively online. You cannot live like way if there is no internet. Since we are all busy working, information can only be sent via the internet at the lowest cost, which saves both money and time.

The future scope is to cover more area than this investigation and to increase the speed of signal transmission to the receivers. This investigation is a working prototype model. This concept is implemented in workplace area to create hazard-less workplace for employees and saves many lives from accidents.

### **Acknowledgement/Funding Acknowledgement**

The author(s) received no financial support for the research, authorship, and/or publication of this article.

### **Declaration of Competing Interest**

The authors declare that they have no known competing financial interests or personal relationships that could have appeared to influence the work reported in this paper.

### **REFERENCES**

- [1] Rajesh, G., Renuka, S., Parthipan, V., & Mizpah, J. (2017). Industrial machine control and monitoring system using IoT. *International Journal of Pure and Applied Mathematics*, 116, 105-111.
- [2] J. Suarez, J. Quevedo, I. Vidal, D. Corujo, J.G. Reinoso, L.R. Aguiar, A secure IoT management architecture based on information-centric networking, *Journal of Network and Computer Applications*, 63 (2016) 190-204.
- [3] Swati, T., & Rao, K. R. (2019). Industrial Process Monitoring System Using Esp32. *International Journal of Recent Technology and Engineering*, 7, 290-294.
- [4] Talreja, S., Dokare, I., Bhat, S., Choudhary, V., & Deopurkar, A. (2020). InMo: IoT based Industrial Safety and Monitoring System. *SAMRIDDHI: A Journal of Physical Sciences, Engineering and Technology*, 12(SUP 1), 273-277.
- [5] Niranjana, M., Madhukar, N., Ashwini, A., Muddasar, J., & Saish, M. (2017). IOT Based Industrial Automation. *IOSR Journal of Computer Engineering (IOSR-JCE)*, 36-40.
- [6] Mohod, S., & Deshmukh, R. S. (2016). Internet of things for industrial monitoring and control applications. *International Journal of Scientific & Engineering Research*, 7(2), 494-498.
- [7] V. Ashalatha, G. Devaraju, Industrial automation monitor and control using IOT, *International Research Journal of Engineering and Technology*, 4 (2017) 308-312.
- [8] Code of Practice for Construction and Approval of Truck Cabs, Truck Bodies and Trailers, The Automotive Research Association of India publication, December 2008.
- [9] Ganesh, S. S., Venkatesh, S., Vidhyasagar, P., & Maragatharaj, S. (2015). Raspberry Pi based interactive home automation system through Internet of Things. *International Journal for Research in Applied Science & Engineering Technology (IJRASET)*, 3(III).